

Rack Data			
模数	module	m	2.0
压力角	pressure angle	α	20°
齿数	number of teeth	Z	150
齿顶修缘	topping		yes
螺旋角	helical angle	β	19°31'42"
旋向	hand of helix		RH
齿顶减薄	tip alteration	km	-
精度等级	accuracy grade		DIN 9
齿距累计偏差	cumulative pitch dev	FpL	0.05/300
齿距总偏差	GT pitch dev	GT/1000	0.1

技术要求：
 1、齿部作高频淬火处理，硬度HRC50-55
 2、去毛刺，棱边倒钝

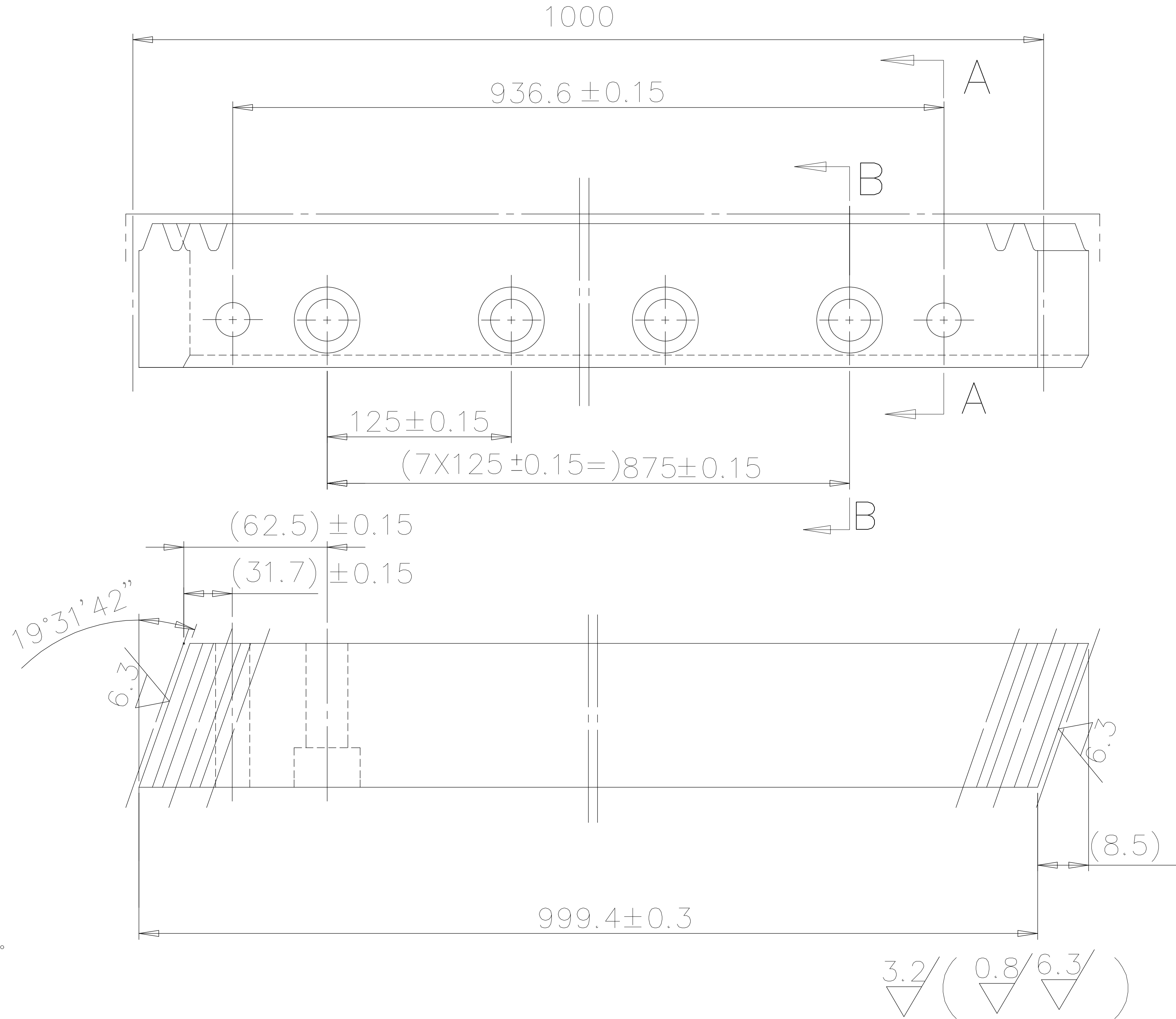

STR'RONSE

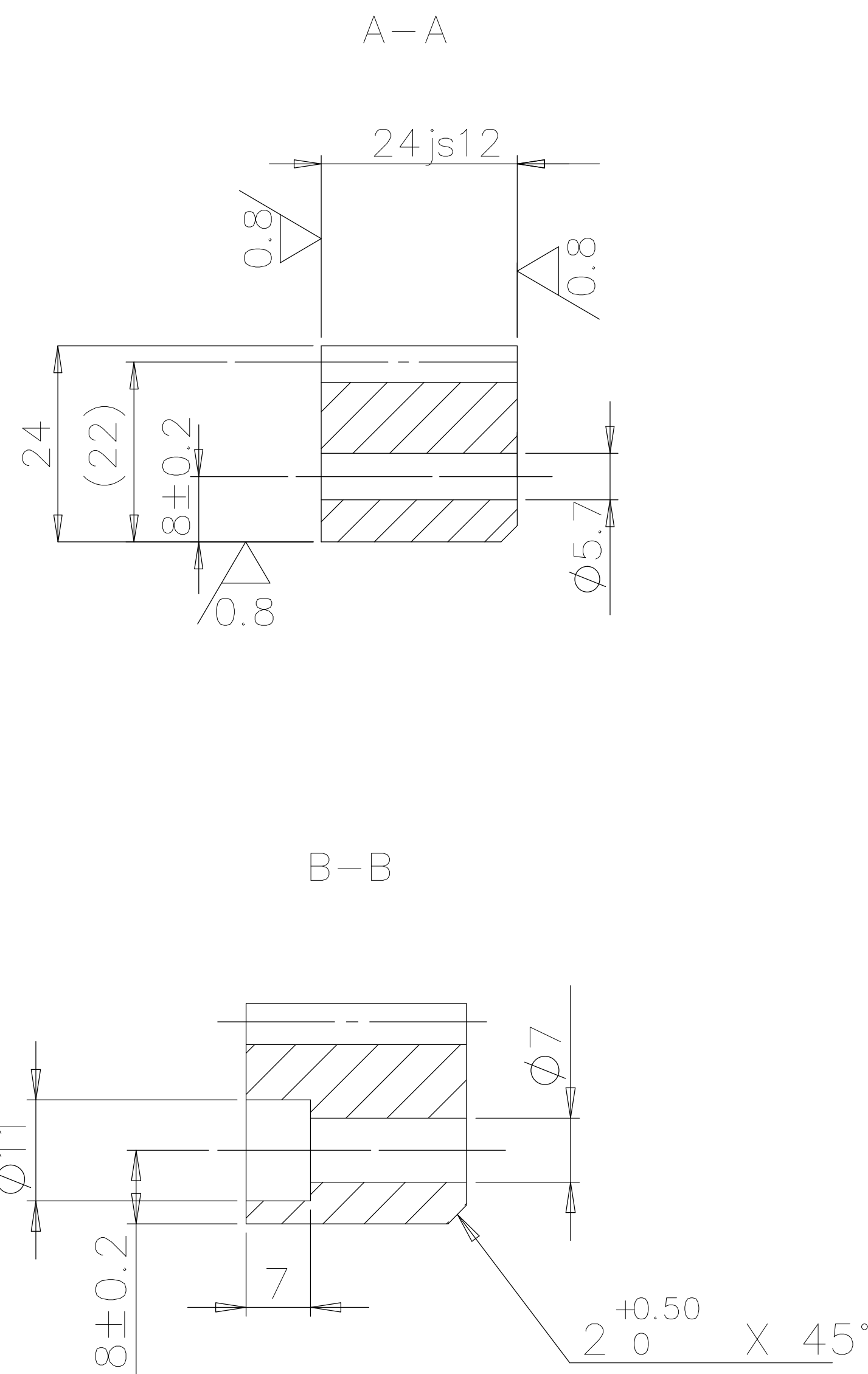
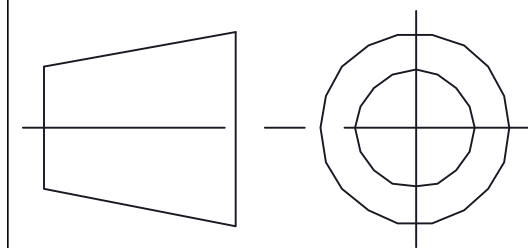

NO.

1902. 401

DRAWN: YAO

DATE:

MATERIAL:

C45

TITLE: 齿条 Rack