

| Rack Data |                      |          |           |
|-----------|----------------------|----------|-----------|
| 模数        | module               | m        | 2.0       |
| 压力角       | pressure angle       | $\alpha$ | 20°       |
| 齿数        | number of teeth      | Z        | 150       |
| 齿顶修缘      | topping              |          | yes       |
| 螺旋角       | helical angle        | $\beta$  | 19°31'42" |
| 旋向        | hand of helix        |          | RH        |
| 齿顶减薄      | tip alteration       | km       | -         |
| 精度等级      | accuracy grade       |          | DIN 8     |
| 齿距累计偏差    | cumulative pitch dev | FpL      | 0.04/300  |
| 齿距总偏差     | GT pitch dev         | GT/1000  | 0.08      |

技术要求：  
 1、调质处理，硬度HRC24-27  
 2、去毛刺，棱边倒钝

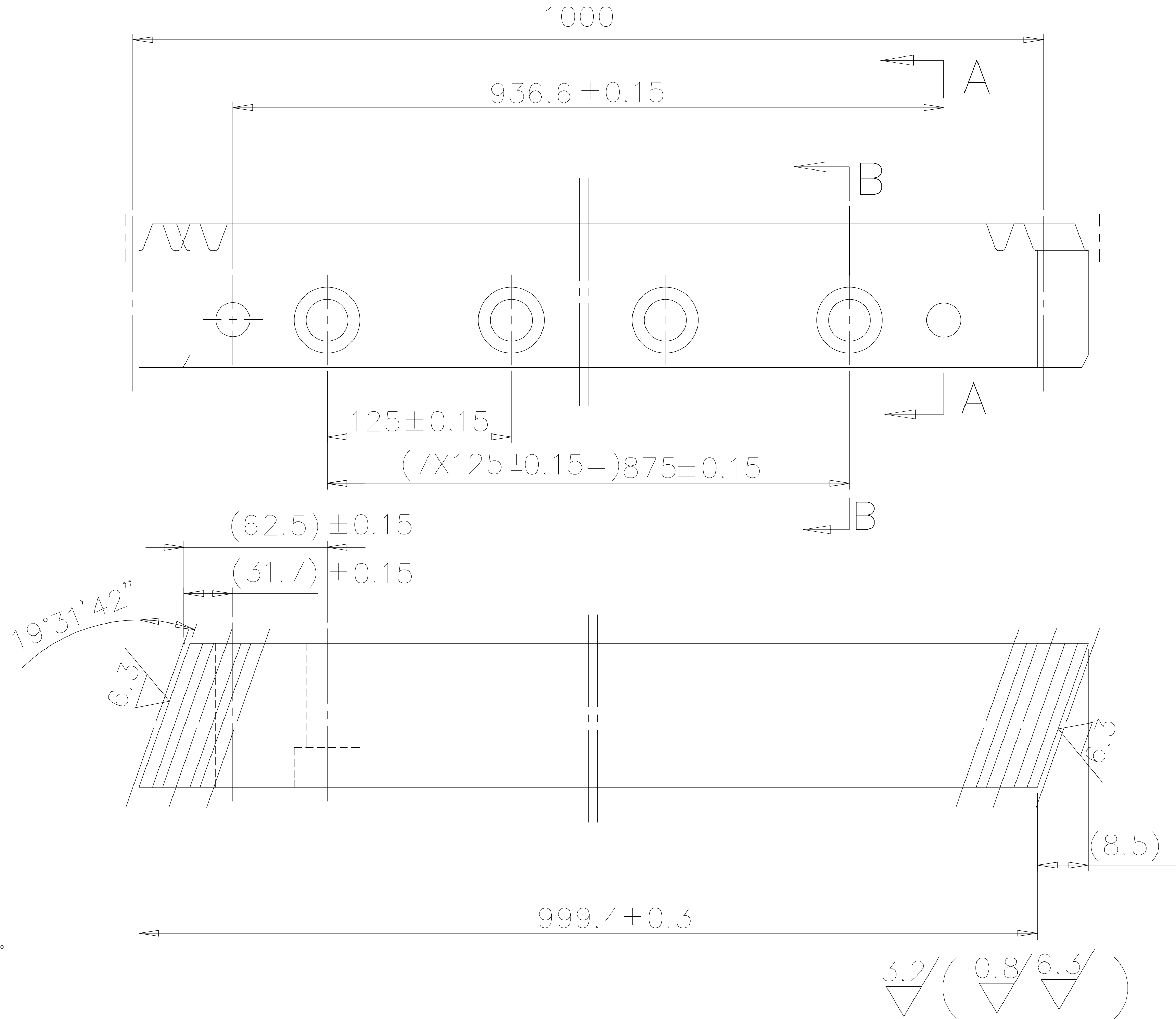
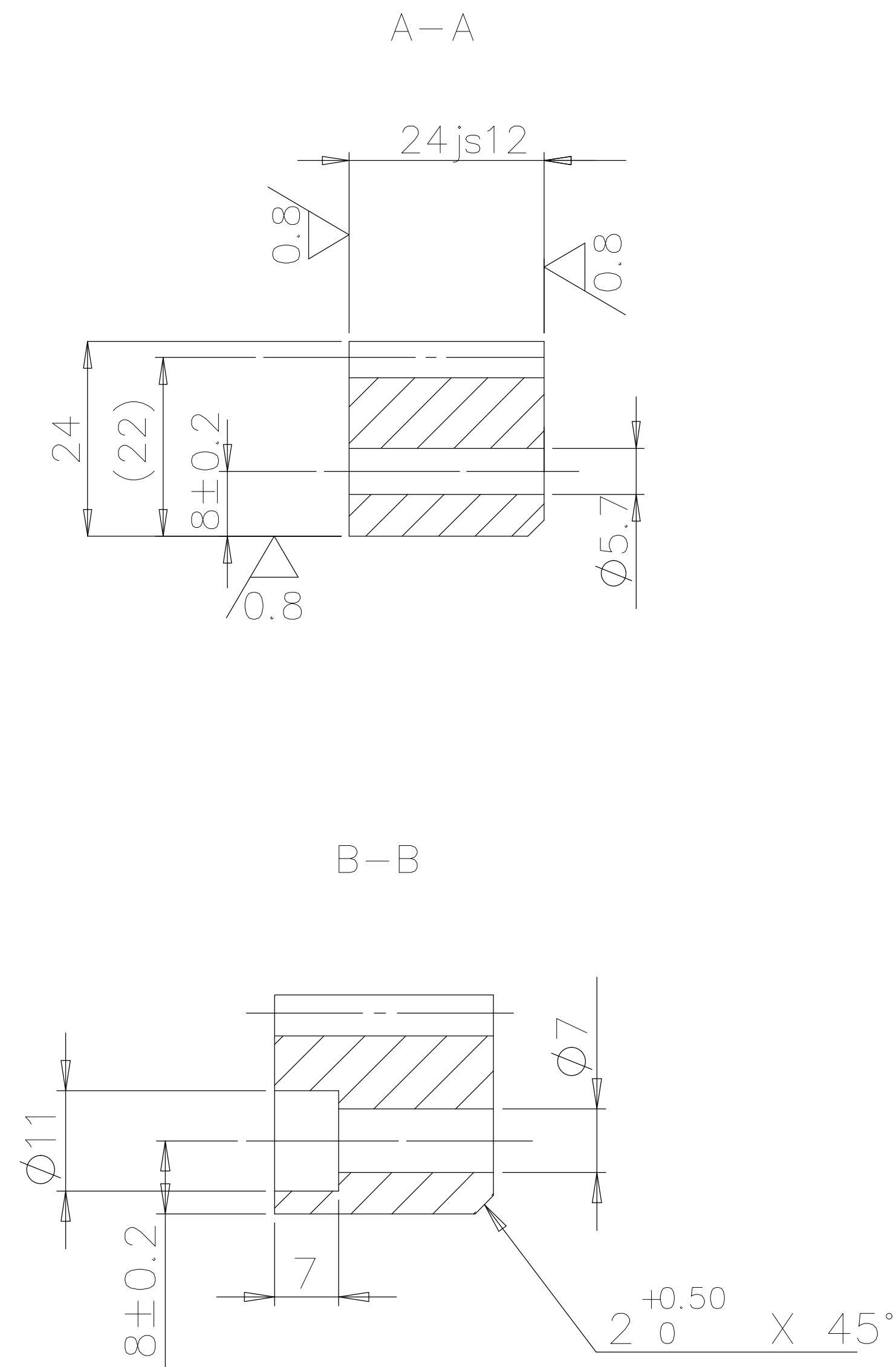

|                  |  |           |           |        |         |       |  |
|------------------|--|-----------|-----------|--------|---------|-------|--|
| <b>STR'RONSE</b> |  | NO.       | 1902. 301 | DRAWN: | YAO     | DATE: |  |
|                  |  | MATERIAL: | C45       | TITLE: | 齿条 Rack |       |  |