

Rack Data			
模数	module	m	3
压力角	pressure angle	α	20°
齿数	number of teeth	Z	108
齿顶修缘	topping		yes
螺旋角	helical angle	β	-
旋向	hand of helix		-
齿顶减薄	tip alteration	km	-
精度等级	accuracy grade		DIN 8
齿距累计偏差	cumulative pitch dev	FpL	0.04/300
齿距总偏差	GT pitch dev	GT/1000	0.08

技术要求：
 1、调质处理，硬度HRC24-27
 2、去毛刺，棱边倒钝

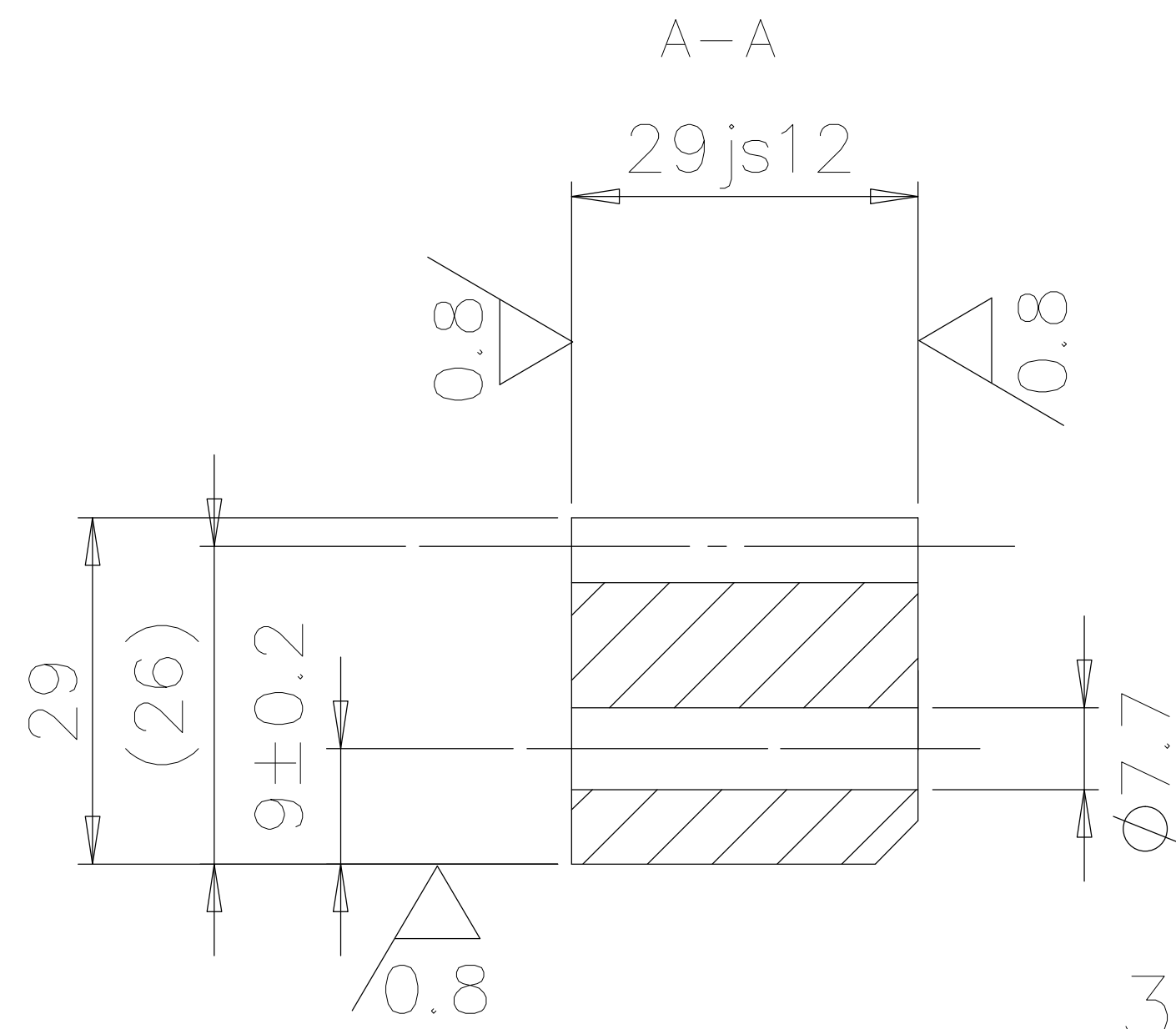

34.4 ± 0.15

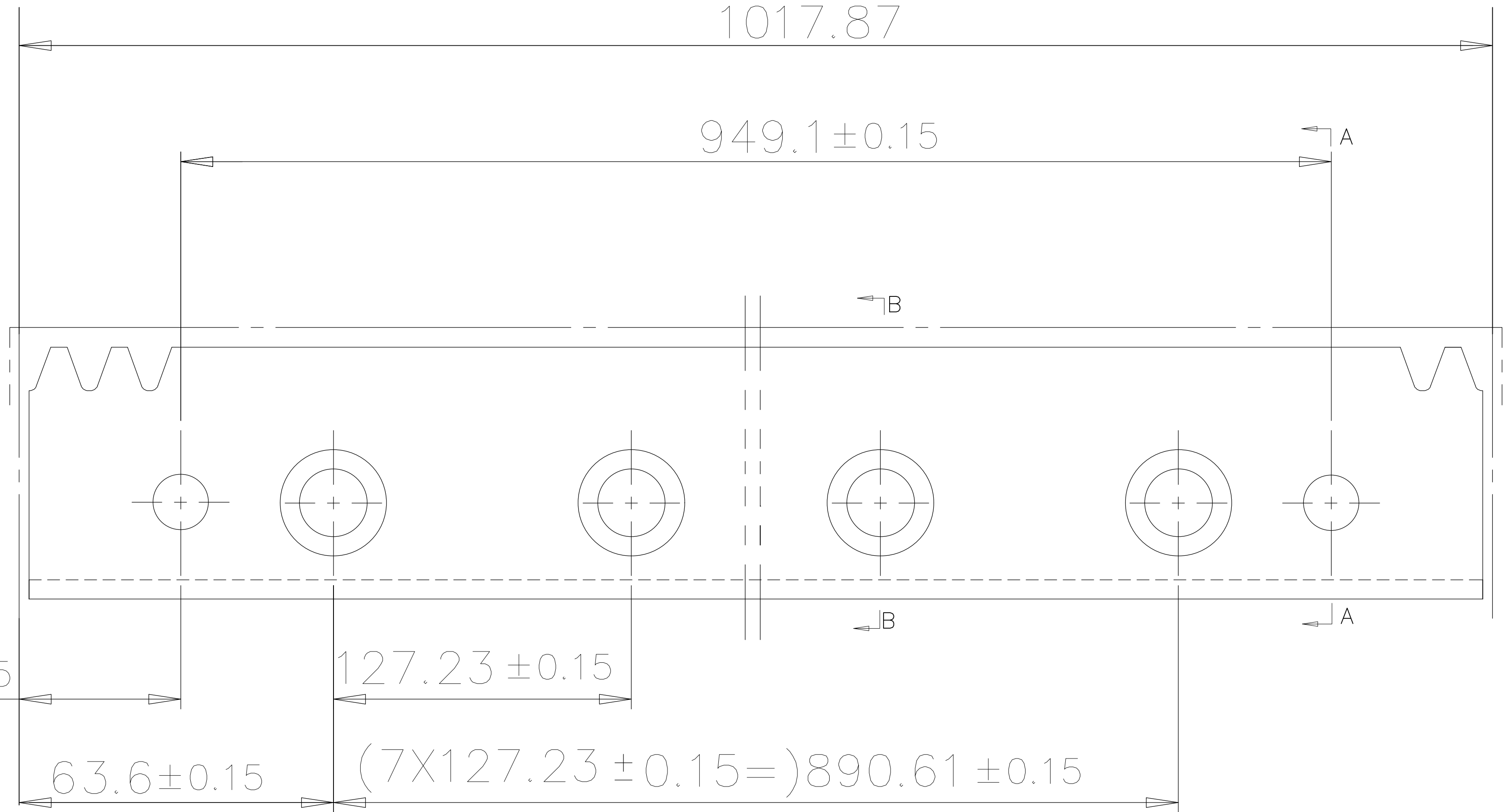

B-B

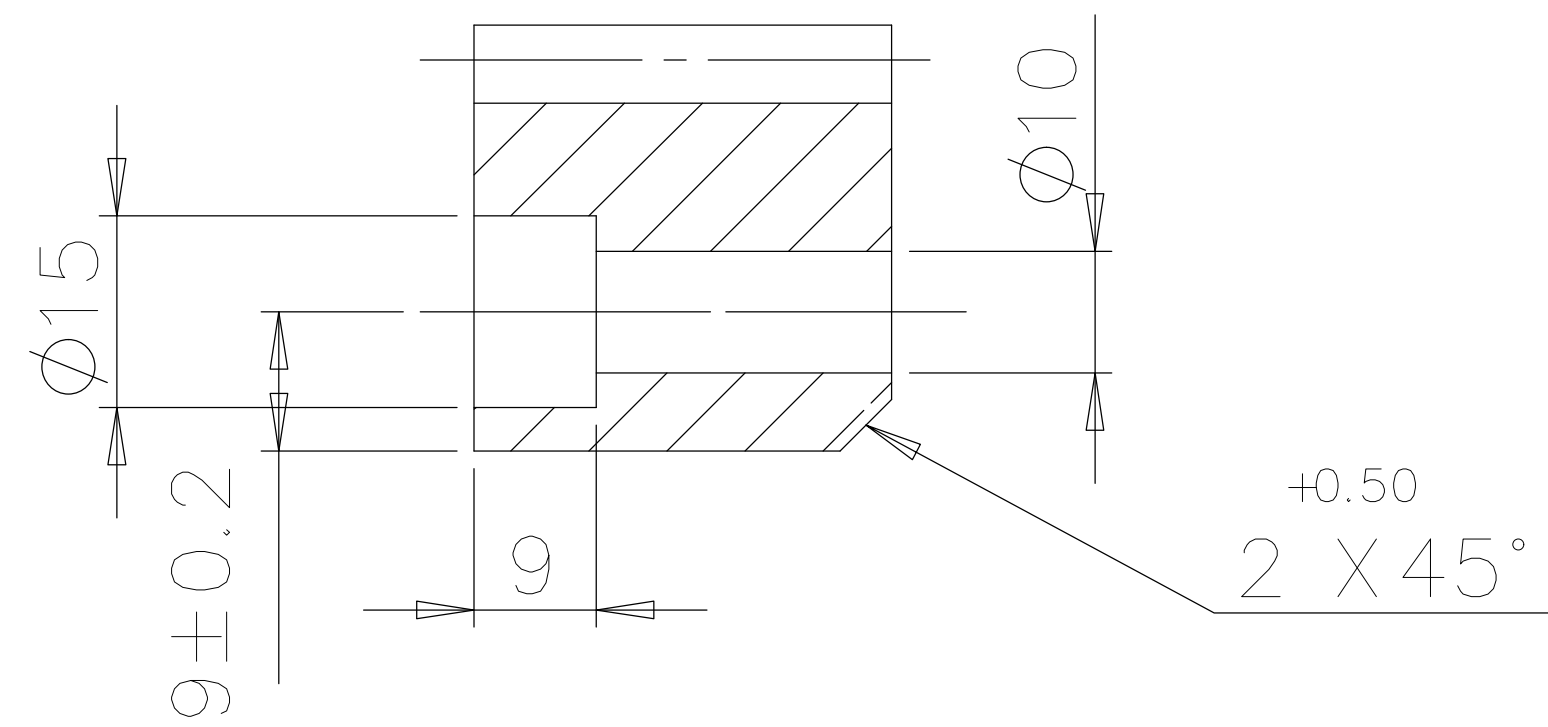

STR'RONSE

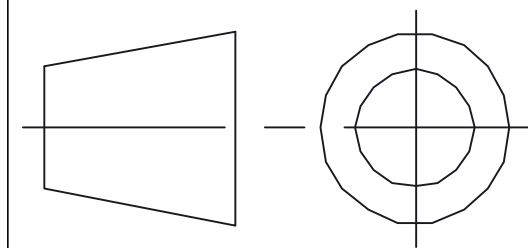

NO.

2003. 301

DRAWN: YAO

DATE:

MATERIAL:

C45

TITLE: 齿条 Rack